



ART AND TECHNOLOGY SINCE 1935

**artek**

## ARTEK – Art and Technology Since 1935

Artek was founded in 1935 by four young idealists, Alvar and Aino Aalto, Maire Gullichsen and Nils-Gustav Hahl. The business idea of the company was “to sell furniture and to promote a modern culture of habitation by exhibitions and other educational means.” The founders of Artek advocated a new kind of environment for everyday life. They believed in a grand synthesis of the arts and wanted to make a difference in town planning as well as architecture and design.



Today Artek is renowned as being one of the most innovative contributors to modern design, building on the heritage of Alvar Aalto. Functionality and timeless aesthetics are the essential elements in the creation of every product that bears the Artek name. Artek's comprehensive furniture system is based on the original idea of standards and systems, which has its origin from Alvar Aalto's L-system. The standard and system thinking makes the furniture range versatile and allows it to be customised for individual projects. Artek's furniture can be found in various types of spaces; from public spaces to homes, museums to schools and hotels to offices.

PRODUCT PORTFOLIO

**artek**

The core of the Artek product range consists of Alvar Aalto's furniture and lighting pieces. Under its new portfolio strategy, Artek is looking to extend the range and, to celebrate the company's 75th anniversary in 2010, has acquired the rights to Ilmari Tapiovaara's furniture collection.

In parallel, Artek also continues to work in close collaboration with prominent international architects, designers and artists, such as Eero Aarnio, Shigeru Ban, Naoto Fukasawa, Harri Koskinen, Juha Leiviskä, Enzo Mari and Tobias Rehberger.

ARMCHAIRS

**artek**

# ARMCHAIRS

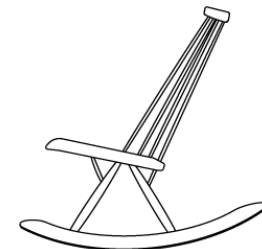
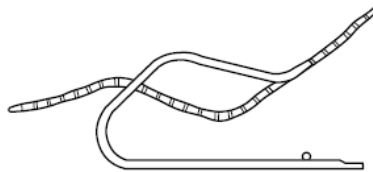
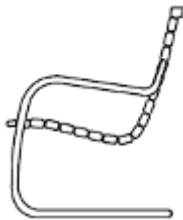
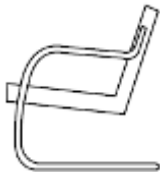

# ARMCHAIR 41 "PAIMIO"

design Alvar Aalto 1932

Armrests birch, natural lacquered

Seat bent birch plywood

Lacquered in white or black

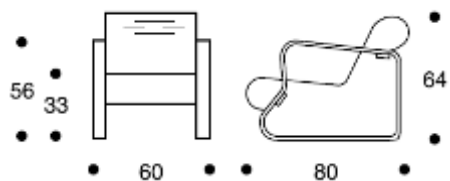

**artek**





Nokia Store, Brazil 2008  
Featuring armchair 41, table 915, tea trolley 901, chair 66 and pendant lamp A338

**artek**



Aino Aalto, Turku Finland 1932

**artek**

# ARMCHAIR 44

design Alvar Aalto 1932

Armrests birch, natural lacquered

Seat with rubber belts, PU foam and dacron

Back with PU foam and dacron

**Upholstered**

with fabric or leather

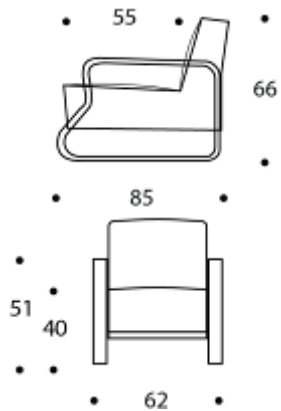

**artek**

# SOFA 544

design Alvar Aalto 1932

Armrests birch, natural lacquered

Seat with rubber belts, PU foam and dacron

Back with PU foam and dacron

**Upholstered**

with fabric or leather

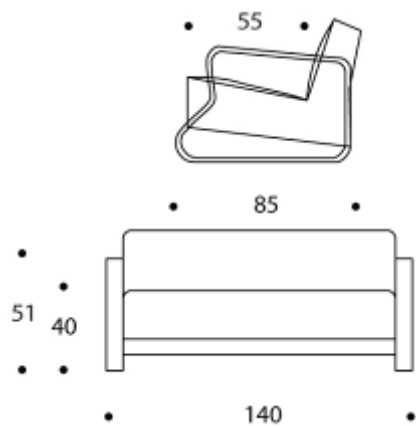

**artek**



Artek Store, 1950-1954  
Featuring sofa 544, armchair 46, table 90B, screen 100

**artek**

# ARMCHAIR 400 "TANK CHAIR"

design Alvar Aalto 1936

Frame birch, natural lacquered

Seat with zig-zag springs, PU foam, dacron

Back with PU foam and dacron

**Upholstered**

with fabric or leather

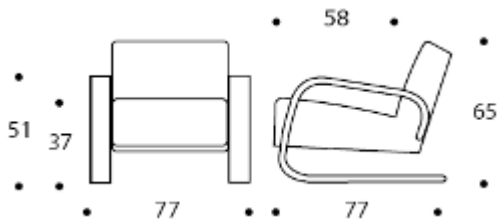

**artek**



Boutique Missoni, Milan Italy 2010  
Featuring armchair 400

# ARMCHAIR 42

design Alvar Aalto 1932

Armrests birch, natural lacquered

Seat bent birch plywood

Lacquered in white or black

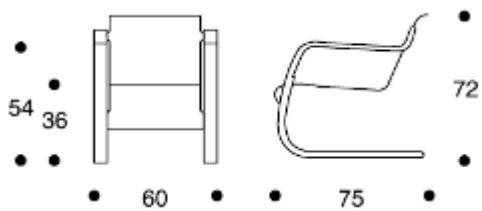

**artek**





Wallpaper stand at ICFF New York, USA  
Featuring armchair 42 and stool 60

**artek**

# ARMCHAIR 402

design Alvar Aalto 1933

Frame birch, natural lacquered

Seat with springs and PU foam

Back with PU foam and Dacron

**Upholstered**

with fabric or leather

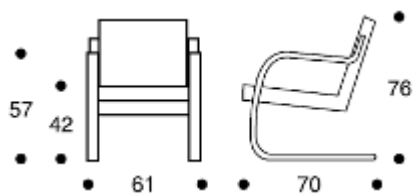

**artek**



Jewish Theatre, Sweden 2002  
Featuring armchair 402

**artek**

# ARMCHAIR 401

design Alvar Aalto 1933

Frame birch, natural lacquered

Seat with springs and PU foam

Back with PU foam and Dacron

**Upholstered**

with fabric or leather

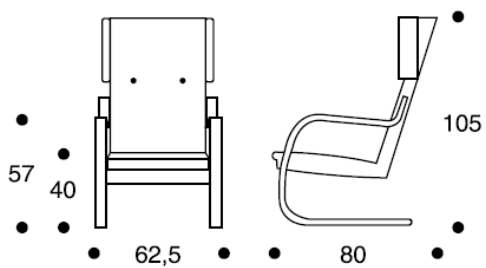

**artek**



Anibou retail space, Australia 2010  
Featuring armchair 401, stool X600, floor lamp A810

**artek**

# ARMCHAIR 406

design Alvar Aalto 1939

Frame birch, natural lacquered

**Upholstery options:**

quilted black linen

quilted black leather

quilted leather belts

linen webbing (white, natural, red, blue, brown or black)

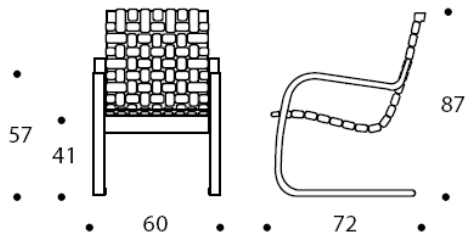

**artek**



Anibou retail space, Australia 2010  
Featuring arnchair 406, table 90C

**artek**

# LOUNGE CHAIR 43

design Alvar Aalto 1937

Frame birch, natural lacquered

Seat options:

with linen webbing

black leather belts

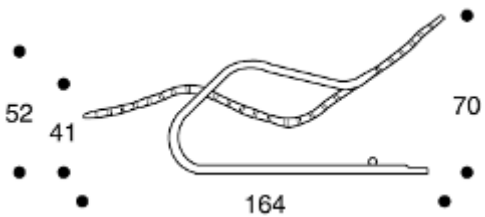

**artek**



# ARMCHAIR 45

design Alvar Aalto 1947

Frame birch, natural lacquered

**Armrests with**  
rattan windings  
black leather windings  
black leather cover

**Seat and back with**  
linen webbing  
quilted black linen  
quilted black leather

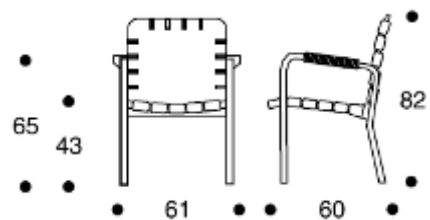

**artek**



Sunstar Suisse office, Switzerland 2009  
Featuring armchair 45 and table X800C

**artek**

# ARMCHAIR 46

design Alvar Aalto 1947

Frame birch, natural lacquered

Seat with zig-zag springs, PU foam

Back with PU foam

**Upholstered with**  
fabric or leather

**Armrests:**  
rattan  
black leather windings  
black leather cover

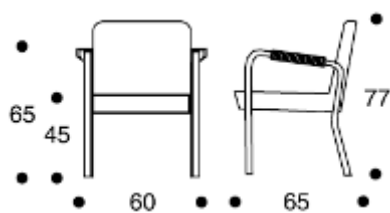

**artek**



Finlandia House restaurant, Helsinki Finland 1971  
Featuring armchair E45

**artek**

# ARMCHAIR E45

design Alvar Aalto 1946

Frame birch, natural lacquered

Seat and back: PU foam

Upholstered with  
fabric or leather

Armrests:

rattan

black leather windings

black leather cover

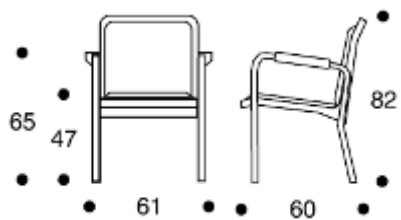

**artek**



Enso-Gutzeit Oy, 1961  
Featuring armchair E45

**artek**

# HALLWAY CHAIR 403

design Alvar Aalto 1932

Frame birch, natural lacquered.

Seat moulded birch plywood  
Lacquered in  
natural colour, white, black, orange,  
yellow or green

Stackable

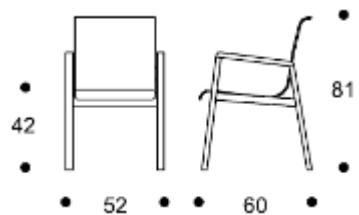

**artek**



Teiloberschule  
FINCKEN

Kavaliershaus, Germany 2010  
Featuring armchair 403

**artek**



# DOMUS LOUNGE CHAIR

design Ilmari Tapiovaara 1946

**Seat and back form pressed birch plywood**

**Frame and armrests of solid birch**

stained honey birch

stained black birch

painted white – stained honey birch

**Upholstered with leather or fabric**

**Frame and armrests of solid birch**

stained black

**Frame and armrest of solid oak**

lacquered

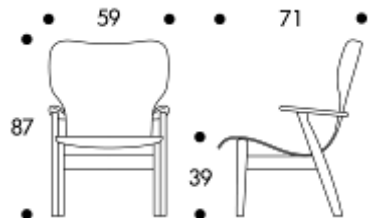

*The characteristic Domus Lounge Chair was designed, alongside the Domus chair, for the public spaces at the Domus Academica's student housing. In the 1940's, it was not possible to produce the large veneer seat/back rest element from one piece. Therefore, the chair is only now being produced as Tapiovaara originally designed it.*

**artek**



Office Varma, Helsinki Finland 2008  
Featuring Domus lounge chair

**artek**

# MADEMOISELLE LOUNGE CHAIR & ROCKING CHAIR

design Ilmari Tapiovaara 1956

Seat, back and frame of solid birch  
stained black  
painted white

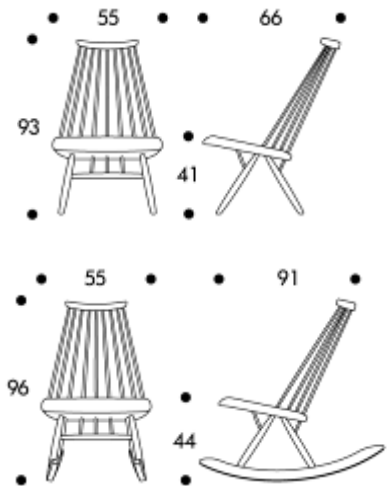

*Spindle and rocking chairs were essential features in the Finnish rustic furniture culture. During his career Tapiovaara designed several renditions of these traditional pieces of furniture. The new designs were modern but also familiar and cozy at the same time. The Mademoiselle chair is one of the most iconic symbols of the 1950's in Finland.*

**artek**



KuuKuu restaurant, Helsinki Finland 2008  
Featuring Mademoiselle lounge chair and TeeTee table

**artek**

CHAIRS

**artek**

# CHAIRS

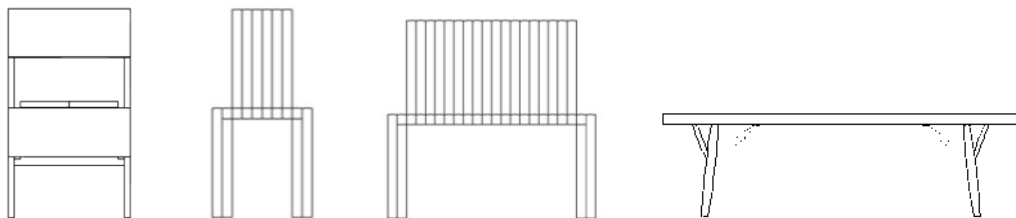
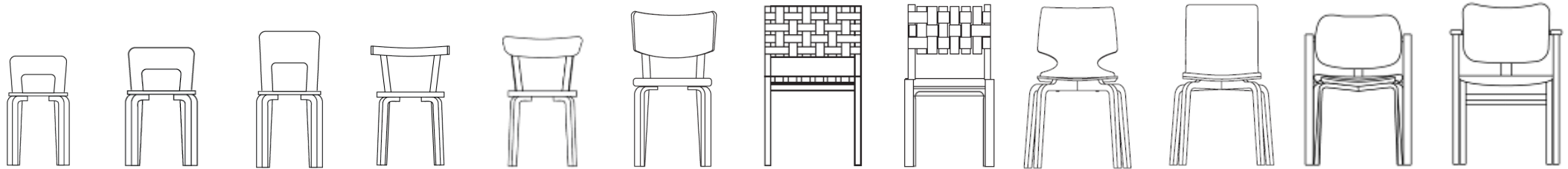
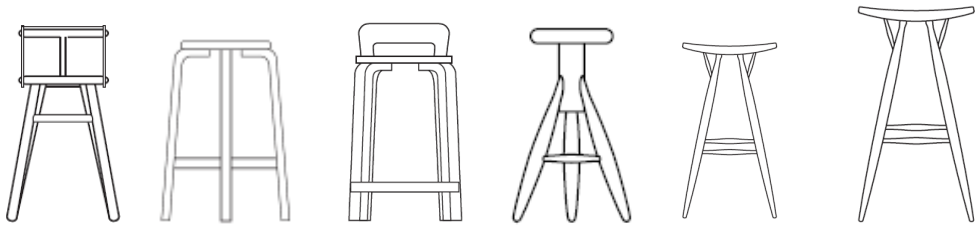
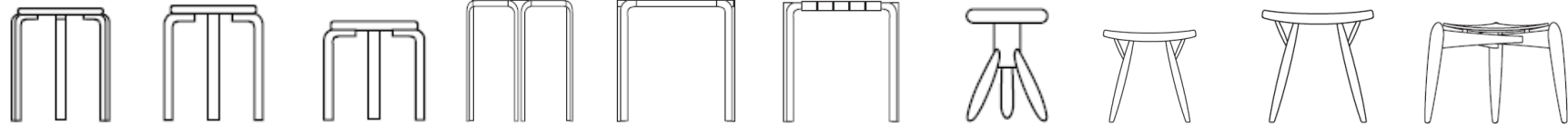

# STOOL 60

design Alvar Aalto 1933

3 legs

Birch, natural lacquered

## Seat options

birch veneer, white laminate,  
black linoleum or red linoleum

Legs and seat lacquered  
in white, grey, black or red

Upholstered  
with fabric or leather

Stackable

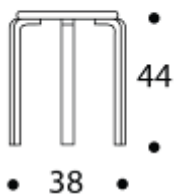
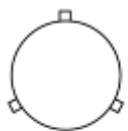

**artek**

# STOOL E60

design Alvar Aalto 1933

4 legs

Birch, natural lacquered

## Seat options

birch veneer, white laminate,  
black linoleum or red linoleum

## Legs and seat lacquered

in white, grey, black or red

## Upholstered

with fabric or leather

Stackable

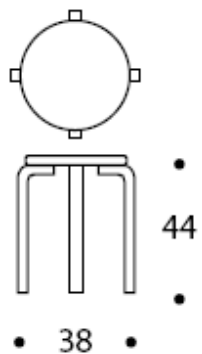

**artek**



# CHILDREN ' S STOOL NE60

design Alvar Aalto 1933

**4 legs**

Birch, natural lacquered

**Seat options:**

birch veneer, white laminate,  
black linoleum or red linoleum

**Upholstered**

with fabric or leather

**Stackable**

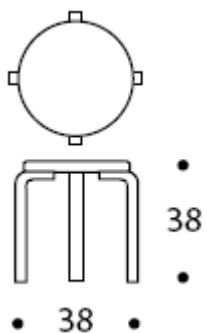

**artek**

# STOOL X600

design Alvar Aalto 1954

3 legs, X-legs

Birch, natural lacquered

Seat options

ash veneer

Upholstered

with black leather

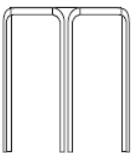

• 45 •

• 38 •

**artek**

# STOOL X601

design Alvar Aalto 1954

4 legs, X-legs

Birch, natural lacquered

Seat options

ash veneer

Upholstered

with black leather

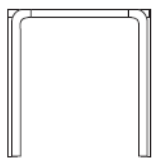
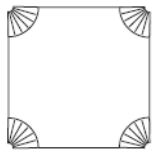

•  
45  
•

• 45 •

**artek**

# STOOL Y61

design Alvar Aalto 1947

4 legs, Y-legs

Birch, natural lacquered

## Seat options

webbing

quilted black canvas

quilted black leather

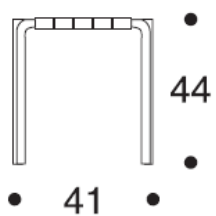
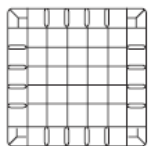

**artek**

# BABY ROCKET

design Eero Aarnio 2006

Oak

soaped

white lacquered

black lacquered

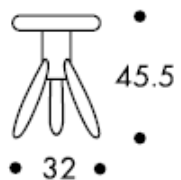

**artek**

# PIRKKA STOOL

design Ilmari Tapiovaara 1955

Seat oilwaxed or stained and lacquered solid

pine, frame lacquered solid birch

seat oilwaxed, frame stained black

seat stained brown, frame stained black

seat honey stained, frame stained black

seat stained brown, frame honey stained

Seat and frame solid birch

painted white

Available in

35 cm

44 cm

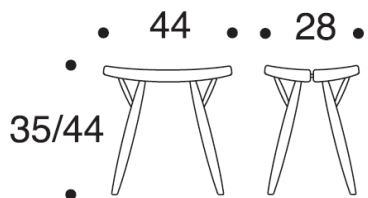

*In the Pirkka range the Finnish rustic form and structure solutions are combined with the light furniture style of the 1950's. Pirkka quickly became a hit and grew to be one of the most liked Finnish furniture ranges. The small pieces of furniture fitted perfectly into the small post war homes and summer places. The furniture made of solid wood and assembled without screws are also remarkably light.*

**artek**

# TALE STOOL

design Ilmari Tapiovaara 1953

Seat form pressed, veneered birch plywood

Frame solid birch

frame and seat stained black

frame stained black, seat walnut veneer

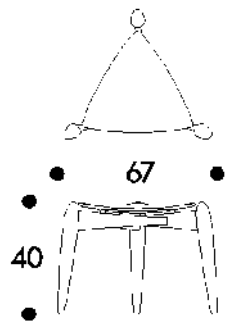

*The name Tale refers to the Finnish tradition of telling stories and tales by the fireplace. The wide stool works as a pleasant seat for this purpose. Tapiovaara had earlier used similar base structure as in the Tale stool in a coffee table designed in 1937. In the table the right triangular seat was replaced with a round top.*

**artek**

# 616 BABY CHAIR

design Ben af Schultén 1956

Legs birch  
natural lacquered

Back bent birch plywood  
natural lacquered  
white lacquered  
red lacquered  
blue lacquered  
black lacquered

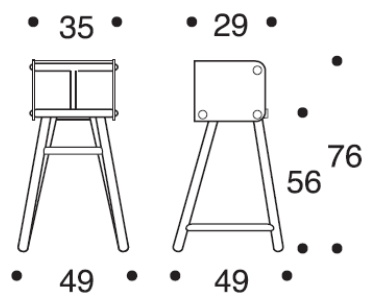

**artek**





**artek**

# 64 HIGH CHAIR

design Alvar Aalto 1935

Birch, natural lacquered

## Seat options

birch veneer  
white laminate  
black linoleum  
red linoleum

## Upholstered

with fabric or leather

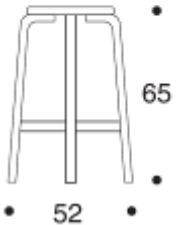
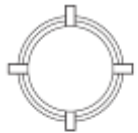

**artek**



Theatré de Poitiers, France, 2008  
Featuring high chair 64

**artek**

# K65 HIGH CHAIR

design Alvar Aalto 1935

Legs birch  
Back birch bent plywood

Seat options:  
birch veneer, white laminate,  
black linoleum or red linoleum

Legs, back and seat lacquered  
in white, grey, black or red

Upholstered  
with fabric or leather

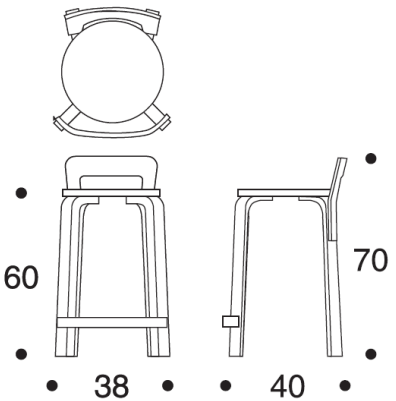



Sushibar + Wine Restaurant, Helsinki Finland, 2010  
Featuring high chair K65

**artek**

# ROCKET

design Eero Aarnio 1995

Oak

soaped

white lacquered

black lacquered

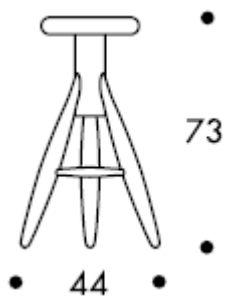

**artek**



Paramount Members Club, UK 2008  
Featuring Rocket

**artek**

# PIRKKA BAR STOOL

design Ilmari Tapiovaara 1955

Seat oilwaxed or stained and lacquered solid pine, frame lacquered solid birch

seat oilwaxed, frame stained black

seat stained brown, frame stained black

seat honey stained, frame stained black

seat stained brown, frame honey stained

Seat and frame solid birch

painted white

Available in

65 cm

80 cm

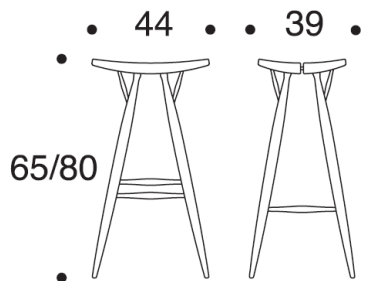

*In the Pirkka range the Finnish rustic form and structure solutions are combined with the light furniture style of the 1950's. Pirkka quickly became a hit and grew to be one of the most liked Finnish furniture ranges. The small pieces of furniture fitted perfectly into the small post war homes and summer places. The furniture made of solid wood and assembled without screws are also remarkably light.*

**artek**



# CHAIR 65

design Alvar Aalto 1935

**Legs birch**  
natural lacquered

**Back birch, bent plywood**  
natural lacquered

**Seat options:**

birch veneer  
laminated  
linoleum

**Upholstered**  
with fabric or leather

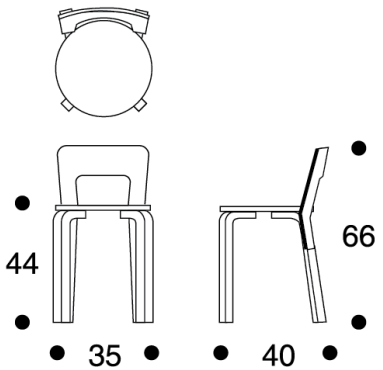

**artek**

# CHILDENR ' S CHAIR N65

design Alvar Aalto 1935

Legs birch, natural lacquered

Back birch, bent plywood, natural lacquered

## Seat options:

birch veneer

white laminate

black linoleum or red linoleum

## Upholstered

with fabric or leather

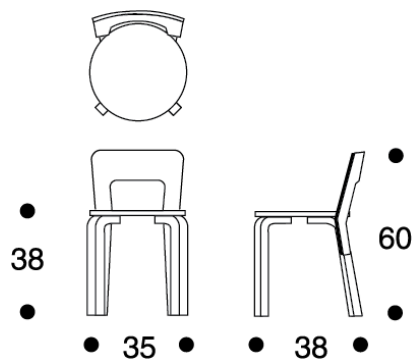

**artek**



Kindergarten Silpark, Austria 2008  
Featuring chair NE65, table 95

**artek**

# CHAIR 66

design Alvar Aalto 1935

Legs birch, natural lacquered  
Back birch, bent plywood, natural lacquered

## Seat options

birch veneer  
white laminate  
black or red linoleum

## Upholstered

with fabric or leather

Legs, seat and back lacquered  
in white or black

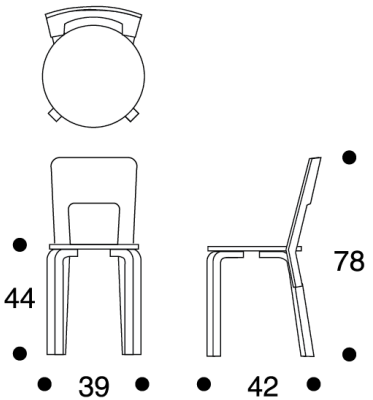

**artek**



Theatre de Poitiers, France 2008  
Featuring chair 66 and table 90A

# CHAIR 68

design Alvar Aalto 1935

Legs and back birch  
natural lacquered

**Seat options:**

birch veneer  
white laminate  
black or red linoleum

**Upholstered**

with fabric or leather

**Stackable**

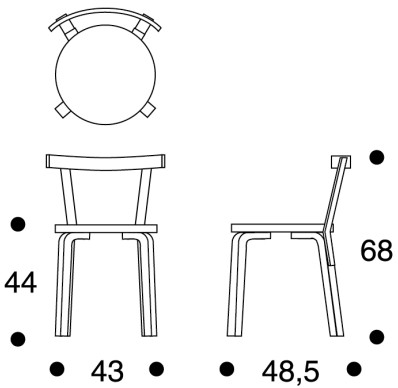

**artek**



Tablo Ateneum Restaurant, Helsinki Finland 2008  
Featuring customized chair 68 and tailored table

**artek**

# CHAIR 69

design Alvar Aalto 1935

Legs and back birch  
natural lacquered

Seat options  
birch veneer  
white laminate

Upholstered  
with fabric or leather

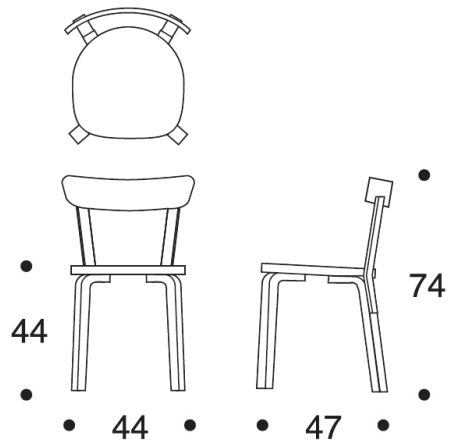

**artek**





Sushibar + Wine Restaurant, Finland, 2010  
Featuring chair 69, pendant lamp A110 and table 81C

**artek**

# CHAIR 63

design Alvar Aalto 1935

Legs birch, natural lacquered  
Seat and back upholstered with padding  
fabric  
leather

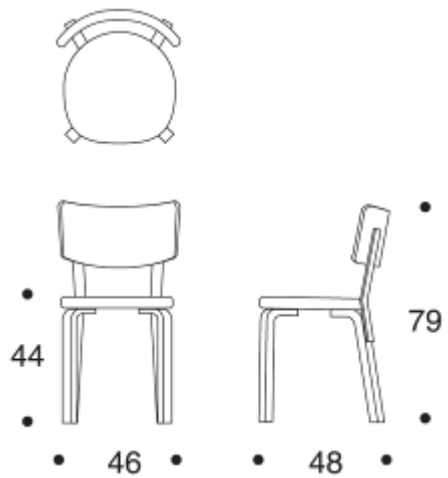

**artek**

# CHAIR 611

design Alvar Aalto 1929

Legs birch, natural lacquered

## Seat and back options

webbing

seat upholstered, back with webbing

## Additional equipment

linking device

hymnal rack

trolley

Stackable

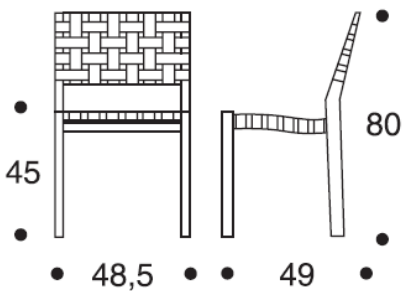

**artek**



Hotel Helka Restaurant, Finland, 2006  
Featuring chair 611, table 81 C

**artek**



**artek**

# CHAIR 615

design Aino Aalto 1939

Legs birch, natural lacquered

Seat and back options  
webbing

Stackable

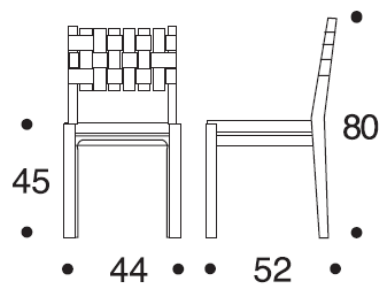

**artek**

# LENTO CHAIR

design Harri Koskinen 2006

Legs form pressed birch veneer  
Seat shell form pressed birch plywood  
natural lacquered  
white lacquered  
black lacquered

Stackable

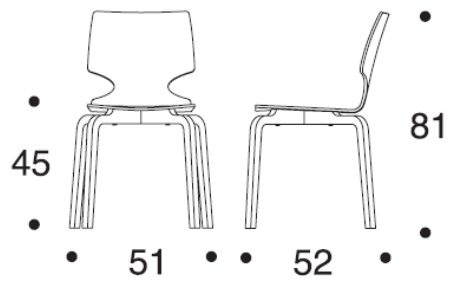

**artek**



The Sushi Bar, Greece 2008  
Featuring Lento chair

**artek**



# LENTO UPHOLSTERED CHAIR

design Harri Koskinen 2009

Legs form pressed birch veneer  
Seat shell form pressed birch plywood  
white lacquered  
black lacquered

**Upholstered**  
with fabric or leather

**Stackable**

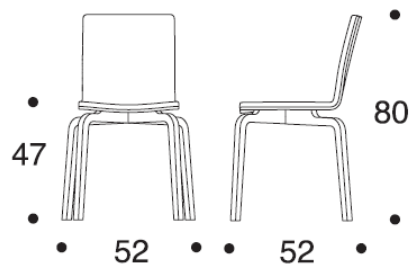

**artek**

# DOMUS CHAIR

design Ilmari Tapiovaara 1946

Stackable multipurpose chair

Seat and back of form pressed birch plywood

Frame and armrest of solid birch

lacquered

stained black

stained honey

painting white

Seat and back of oak veneered birch plywood

Frame and armrest of solid oak

lacquered

Upholstered versions available

seat upholstery with fabric or leather

seat and back upholstery with fabric or leather

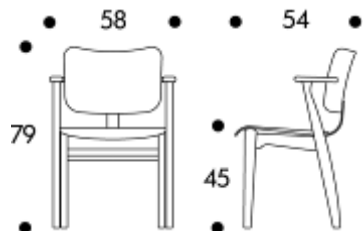

*In the Finnish classic – the Domus chair – the basis was to be a true multi-purpose chair to meet the diverse needs of the Domus Academica student housing in Helsinki. It was to serve as a work chair in the student rooms, but also in the hallways, auditoriums, canteens, negotiation rooms etc. The Domus became a real success in Finland and the first remarkably exported Finnish piece of furniture was also produced with license in other parts of the world, for instance by Knoll International in the USA.*

**artek**



Hilton Airport, Helsinki-Vantaa airport, Finland 2007  
Featuring Domus chair

**artek**

# ASLAK CHAIR

design Ilmari Tapiovaara 1958

Stackable multipurpose chair  
Available with and without upholstery

Seat and back of form pressed birch plywood,  
frame of laminated birch

lacquered  
stained black  
painted white

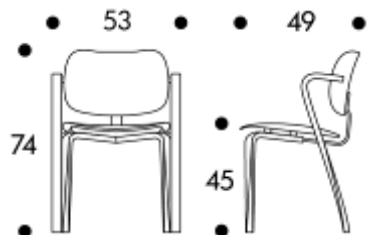

*In the original Aslak chair Tapiovaara combined the solutions of his earlier designs of Domus and Lukki chairs. The contiguous back leg – armrest had already been sketched in 1946, but only in 1958 the new laminating methods of veneer made it possible for mass production. As it's predecessors Aslak got good reviews from the public and it quickly became a sales hit.*

**artek**



Restaurant Ateljee Finne, Helsinki Finland 2009  
Featuring Aslak chair

**artek**

# PIRKKA CHAIR

design Ilmari Tapiovaara 1955

Seat and back oilwaxed or stained and lacquered solid pine, frame lacquered solid birch  
seat and back oilwaxed, frame stained black  
seat and back stained brown, frame stained black  
seat and back honey stained, frame stained black  
seat and back stained brown, frame honey stained

Seat, back and frame solid birch  
painted white

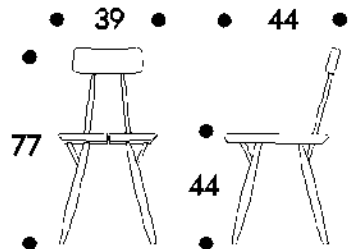

*In the Pirkka range the Finnish rustic form and structure solutions are combined with the light furniture style of the 1950's. Pirkka quickly became a hit and grew to be one of the most liked Finnish furniture ranges. The small pieces of furniture fitted perfectly into the small post war homes and summer places. The furniture made of solid wood and assembled without screws are also remarkably light.*

**artek**

# SEDIA 1 CHAIR

design Enzo Mari 1974

Pine, unfinished

Chair is delivered as pre-cut pine boards  
along with assembly instructions

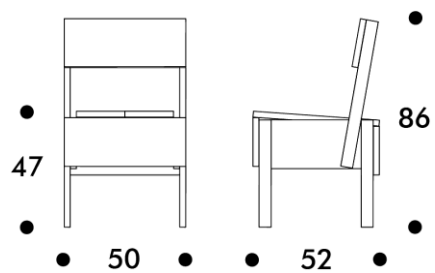

**artek**

# 10-UNIT SYSTEM CHAIR

design Shigeru Ban 2009

UPM ProFi wood plastic composite

white

black

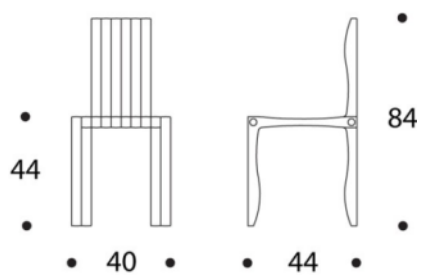

**artek**



# 10-UNIT SYSTEM BENCH

design Shigeru Ban 2009

UPM ProFi wood plastic composite

white

black

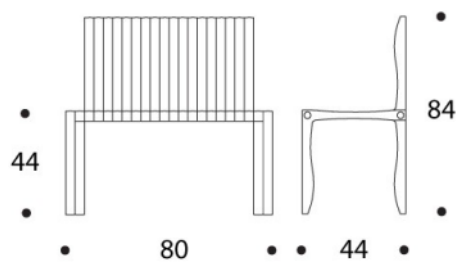

**artek**



Cafe Cubus Ateneum, Helsinki Finland, 2009  
Featuring 10 Unit System, pendant lamp A330S, tailored table

**artek**

# PIRKKA BENCH

design Ilmari Tapiovaara 1955

Seat oilwaxed or stained and lacquered solid pine, frame of lacquered solid birch

seat oilwaxed, frame stained black

seat stained brown, frame stained black

seat honey stained, frame stained black

seat stained brown, frame honey stained

Frame birch and top birch

painted white

Available in

120 cm – 2-seat

150 cm – 2-3-seat

180 cm – 3-4-seat

240 cm – 4-seat



• 26 •

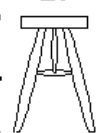

44

• 120/150/180/240 •

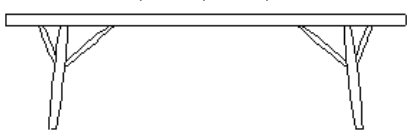

*In the Pirkka range the Finnish rustic form and structure solutions are combined with the light furniture style of the 1950's. Pirkka quickly became a hit and grew to be one of the most liked Finnish furniture ranges. The small pieces of furniture fitted perfectly into the small post war homes and summer places. The furniture made of solid wood and assembled without screws are also remarkably light.*

**artek**



Nordic Bakery, London UK 2010  
Featuring Pirkka table, bench and stool

**artek**

TABLES

**artek**

# TABLE 90A, B, C, D

design Alvar Aalto 1935

3 legs

Birch, natural lacquered

90A with 4 legs

90 B, C, D with 3 legs

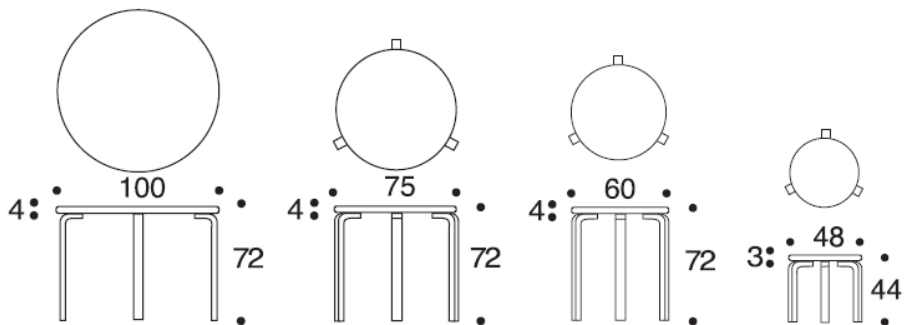

# TABLE 91

design Alvar Aalto 1935

4 legs, L-legs, birch, natural lacquered

## Table top

edge birch, natural lacquered  
diameter 125 cm, thickness 5 cm

## Coating options

natural lacquered  
white laminate  
black linoleum

Available with HL2-legs, birch

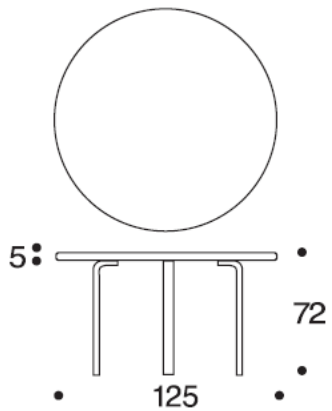

**artek**

# TABLE 95, 96

design Alvar Aalto 1935

L-legs birch, natural lacquered

## Table top

edge birch, natural lacquered

95 table diameter 120 cm, thickness 4 cm

96 table diameter 150 cm, thickness 5 cm

## Coating options

birch veneer

white laminate

black linoleum

95 table can be combined with

tables 80A, 80B, 81B or 84

96 table can be combined with

table 82

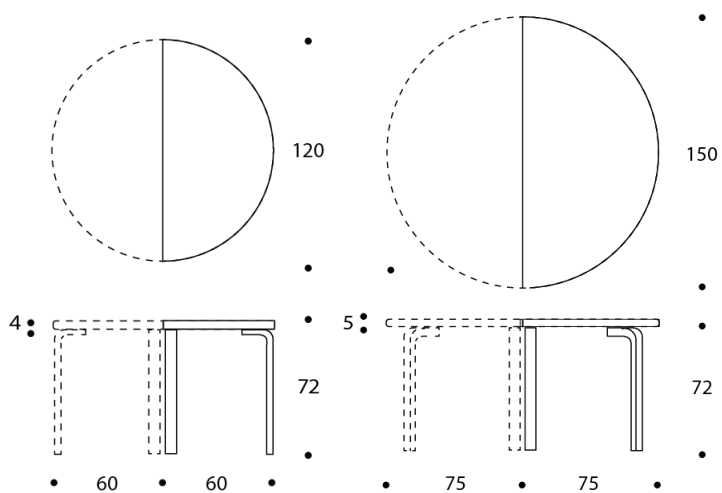



# TABLE 80A

design Alvar Aalto 1935

L-legs birch, natural lacquered

## Table top

edge birch, natural lacquered  
120 x 60 cm, thickness 4 cm

## Coating options

birch veneer  
white laminate  
black linoleum

Available with HL2-legs, birch

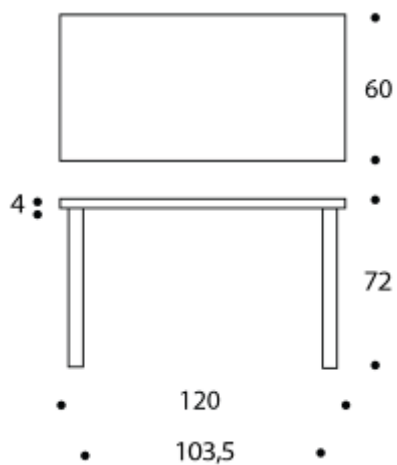

**artek**

# TABLE 80B

design Alvar Aalto 1935

L-legs birch, natural lacquered

## Table top

edge birch, natural lacquered  
100 x 60 cm, thickness 4 cm

## Coating options

birch veneer  
white laminate  
black linoleum

Available with HL1-legs, birch

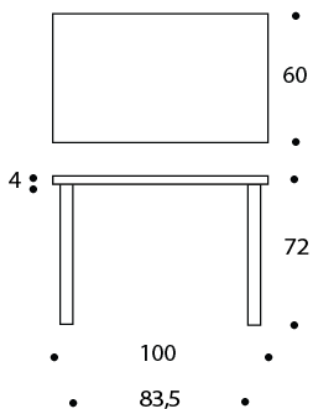

**artek**

# TABLE 81A

design Alvar Aalto 1935

L-legs birch, natural lacquered

## Table top

edge birch, natural lacquered  
150 x 75 cm, thickness 4 cm

## Coating options

birch veneer  
white laminate  
black linoleum

Available with HL1-legs, birch

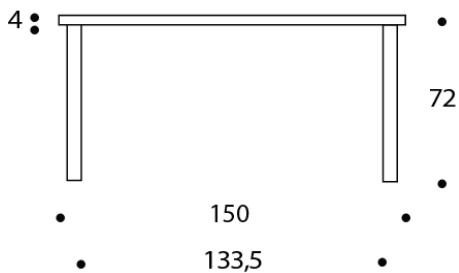
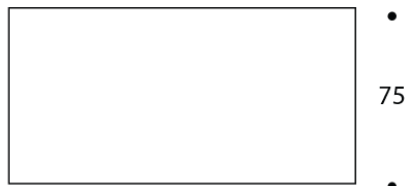

**artek**

# TABLE 81 B

design Alvar Aalto 1935

L-legs birch, natural lacquered

## Table top

edge birch, natural lacquered  
120 x 75 cm, thickness 4 cm

## Coating options

birch veneer  
white laminate  
black linoleum

Available with HL1-legs, birch

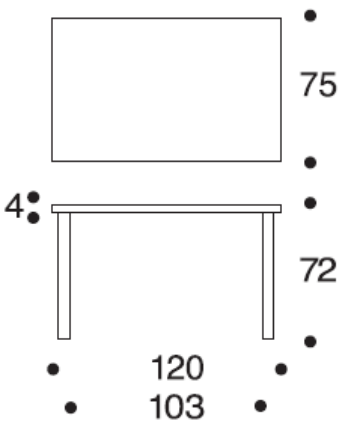

**artek**

# TABLE 81 C

design Alvar Aalto 1935

L-legs birch, natural lacquered

## Table top

edge birch, natural lacquered  
75 x 75 cm, thickness 4 cm

## Coating options

birch veneer  
white laminate  
black linoleum

Available with HL1-legs, birch

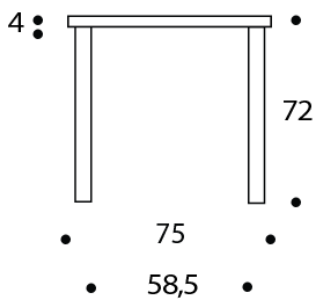
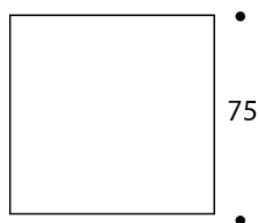

# TABLE 82A

design Alvar Aalto 1935

L-legs birch, natural lacquered

## Table top

edge birch, natural lacquered  
150 x 85 cm, thickness 5 cm

## Coating options

birch veneer  
white laminate  
black linoleum

Available with HL2-legs, birch

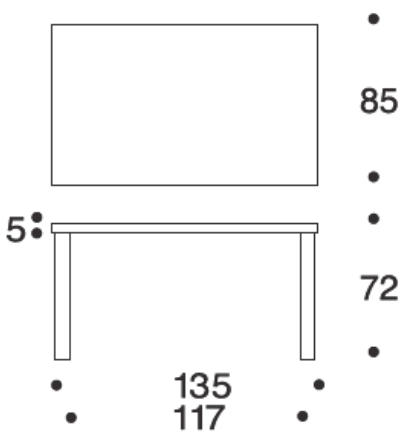

**artek**

# TABLE 82B

design Alvar Aalto 1935

L-legs birch, natural lacquered

## Table top

edge birch, natural lacquered  
135 x 85 cm, thickness 5 cm

## Coating options

birch veneer  
white laminate  
black linoleum

Available with HL2-legs, birch

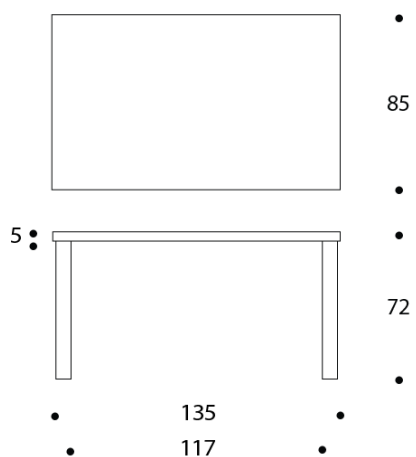

**artek**

# TABLE 83

design Alvar Aalto 1935

L-legs birch, natural lacquered

## Table top

edge birch, natural lacquered  
182 x 91 cm, thickness 5 cm

## Coating options

birch veneer  
white laminate  
black linoleum

Available with HL2-legs, birch

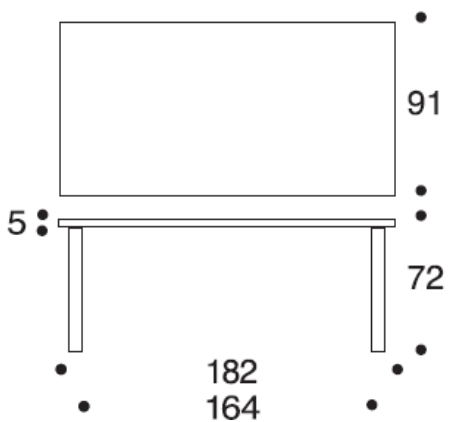

**artek**



# TABLE 84

design Alvar Aalto 1935

L-legs birch, natural lacquered

## Table top

edge birch, natural lacquered  
150 x 85 cm, thickness 5 cm

## Coating options

birch veneer  
white laminate  
black linoleum

Available with HL2-legs, birch

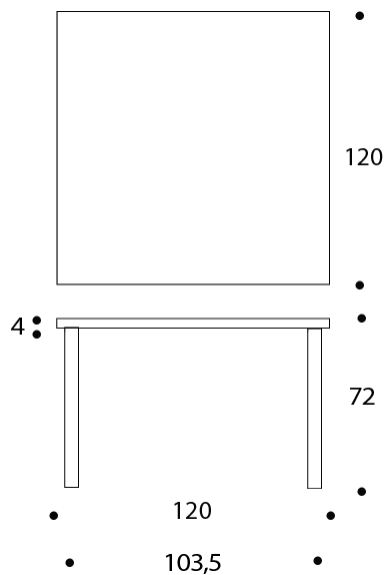

# TABLE E86

design Alvar Aalto 1935

L-legs birch, natural lacquered

## Top

200 x 100 cm, thickness 5 cm

## Coating options

birch veneer

white laminate

Available with HL2-legs, birch

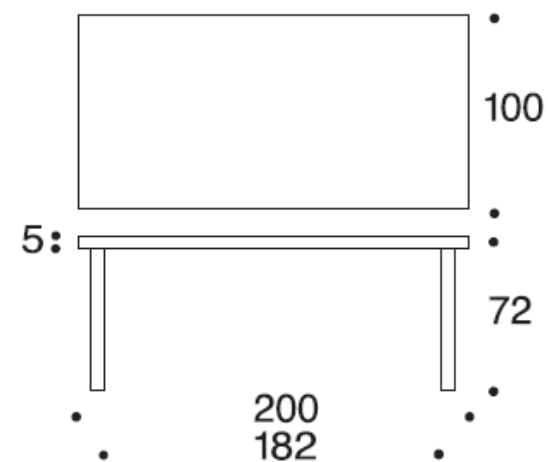

# LENTO TABLE

design Harri Koskinen 2009

Table top birch plywood

Birch legs painted black or white

## Top materials

white laminate, edge birch plywood

black laminate, edge stained black

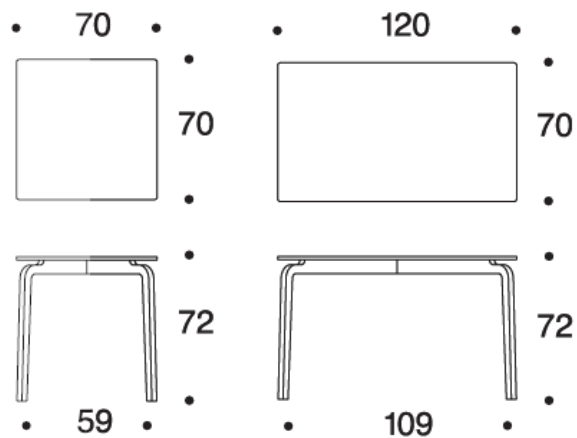

# EXTENSION TABLE 97

design Alvar Aalto 1935

L-legs birch, natural lacquered

Table top 135 x 85 cm, thickness 5 cm

Top material

birch veneer

white laminate

1 extension leaf

55 x 85 cm

to be stored separately

Available with HL2-legs, birch

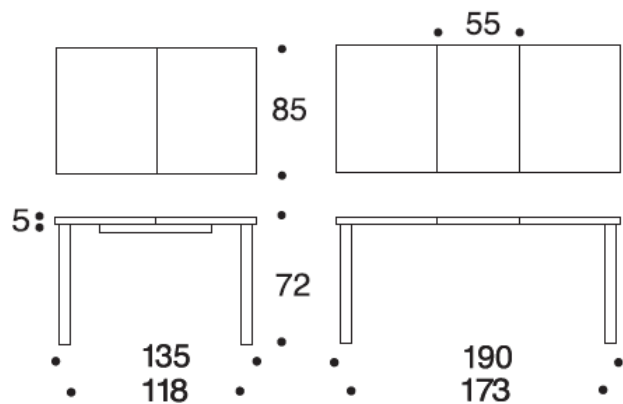

**artek**

# EXTENSION TABLE H92

design Alvar Aalto 19356

HL2-legs and table top ash veneer

## Table top

130 x 90, thickness 6 cm

## Two extension leaves

50 x 90 cm

Extension leaves can be stored discreetly underneath the table

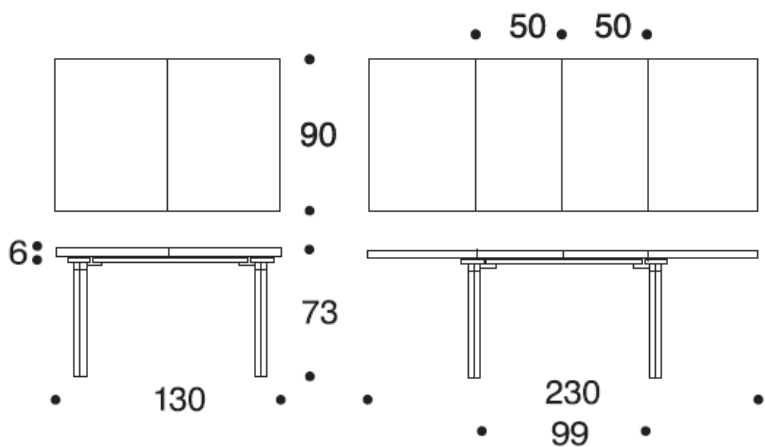

# EXTENSION TABLE H94

design Alvar Aalto 1956

HL2-legs and table top ash veneer

## Table top

190 x 100, thickness 6,8 cm

## Two extension leaves

58 x 100 cm

Extension leaves can be stored discreetly underneath the table

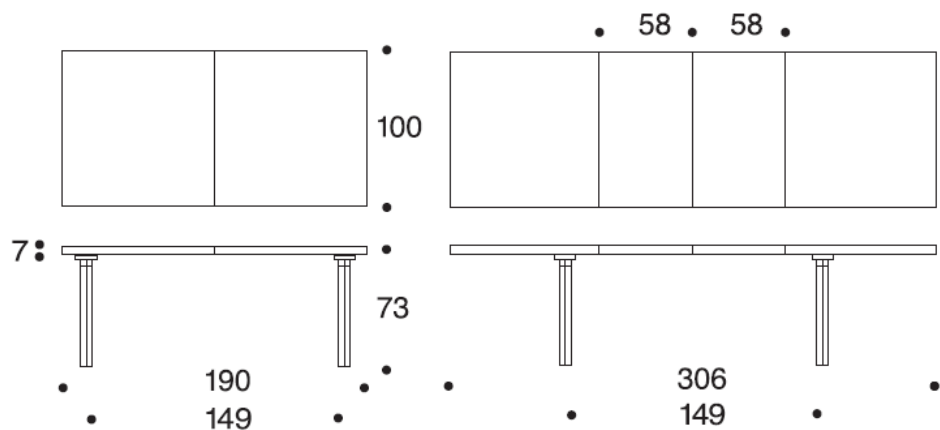

# EXTENSION TABLE H99

design Alvar Aalto 1956

HL2-legs birch, natural lacquered

Table top 165 x 105, thickness 5 cm

## Top material

birch veneer

white laminate

## 1 extension leaf

45 x 105 cm

Extension leaves can be stored discreetly underneath the table

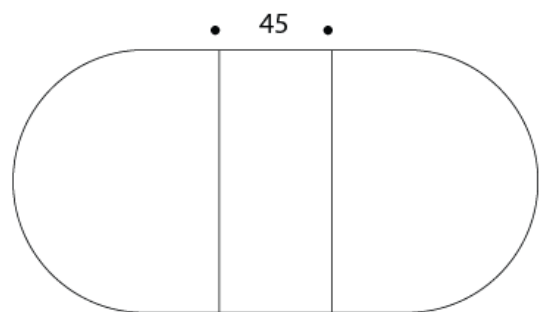

# PIRKKA TABLE

design Ilmari Tapiovaara 1955

Top oilwaxed or stained and lacquered solid pine, frame lacquered solid birch

top oilwaxed, frame stained black

top stained brown, frame stained black

top honey stained, frame stained black

top stained brown, frame honey stained

Top and frame solid birch,

top and frame painted white

Available in

120 x 70 cm

150 x 80 cm

180 x 80 cm

240 x 80 cm

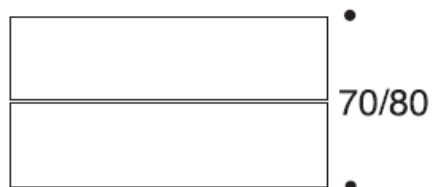

• 120/150/180/240 •



*In the Pirkka range the Finnish rustic form and structure solutions are combined with the light furniture style of the 1950's. Pirkka quickly became a hit and grew to be one of the most liked Finnish furniture ranges. The small pieces of furniture fitted perfectly into the small post war homes and summer places. The furniture made of solid wood and assembled without screws are also remarkably light.*

**artek**



# TABLE MX800A, B, C

design Alvar Aalto 1954

X-legs birch, natural lacquered

Table top ash veneer, natural lacquered



80



90

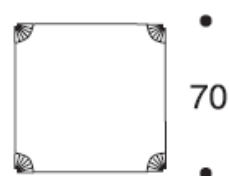

70



52

135

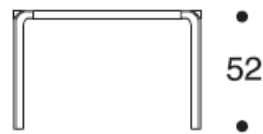

52

90



52

70

**artek**

# NESTING TABLE 88A, B, C

design Alvar Aalto 1935

3 legs

Birch, natural lacquered

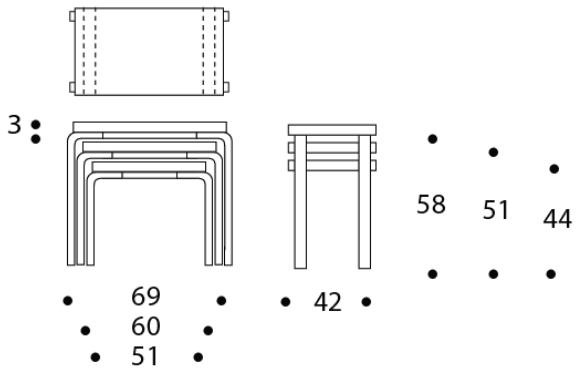

**artek**

# 10-UNIT TABLE

design Shigeru Ban 2009

UPM ProFi wood plastic composite

white

black

Table top

tempered glass

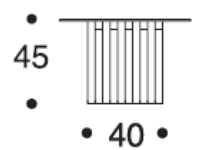
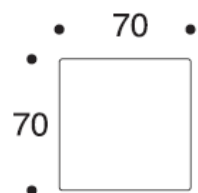

**artek**

# GLASS TABLE Y805A, B, C

design Alvar Aalto 1946

Y-legs

Birch stand, natural lacquered

Glass top, clear glass

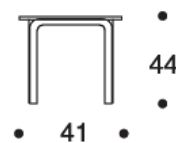
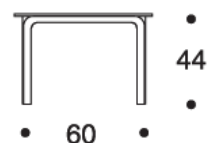
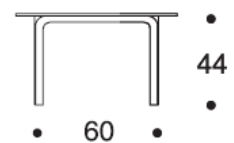
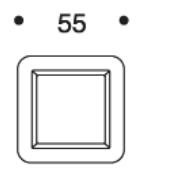
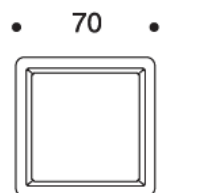
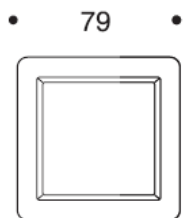

# X-FRAME GLASS TOP TABLE

design Alvar Aalto 1958

## Frame options

solid elm, natural lacquered

solid oak, natural lacquered

laminated birch/ cherry wood, natural lacquered

## Glass top

tempered glass

124 x 66 cm

8 mm

Frame individually hand-sculptured

Numbered

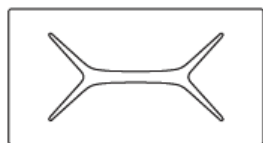

**artek**

# TEE-TEE TABLE

design Ilmari Tapiovaara 1940

Top birch veneered plywood,  
frame solid birch  
stained black  
stained honey  
painted white

Top oak veneered plywood, frame  
solid oak  
lacquered oak

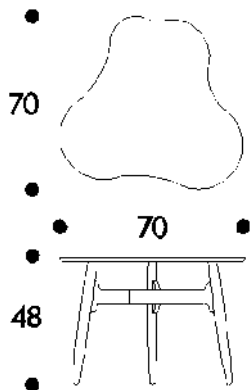

*The Tee-Tee table was originally a unique design for the Finnish industrial art exhibition in 1940. Ilmari Tapiovaara had designed a living room furniture set including a sofa, armchair, cabinet, pendant light and a table – nowadays known as Tee-Tee – for the first prize of a lottery to be held after the exhibition.*

**artek**

# TRIENNA COFFEE TABLE

design Ilmari Tapiovaara 1954

Form pressed, veneered birch plywood

natural lacquered birch veneer

stained black

painted white

natural lacquered oak veneer

natural lacquered walnut veneer

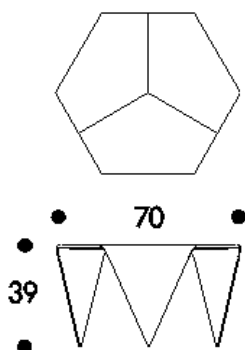

*In the 1950's alongside chairs Tapiovaara repeatedly made sketches for light and easy to move coffee tables. Another baseline in designing the Trienna coffee table was that larger honeycomb-like groups could be formed of them if needed. A few model versions were made in 1954, but the actual serial production only started in 2007. In 2008 The Wallpaper Magazine awarded the table the prize of "Best reissue table".*

**artek**

# DOMINO TABLE

design Ilmari Tapiovaara 1954

Table top of solid birch and plywood

Surface and background veneer, total thickness 15 mm

Frame of solid wood

frame walnut, top walnut veneered

frame oak, top oak veneered

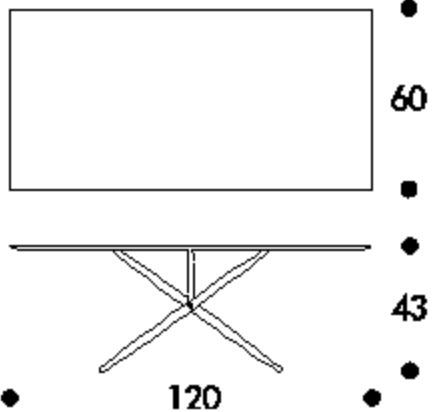

*The ovalette and Domino coffee tables are made by cabinetmakers with attention to detail. They originally belonged to the same furniture family as the wooden Kongo chair. In the first sketches they were called Kongo tables, but in the final drawings the names were changed.*

**artek**



# OVALETTE TABLE

design Ilmari Tapiovaara 1954

Table top of solid birch and plywood

Surface and background veneer, total thickness 15 mm

Frame of solid wood

frame walnut, top walnut veneered

frame oak, top oak veneered

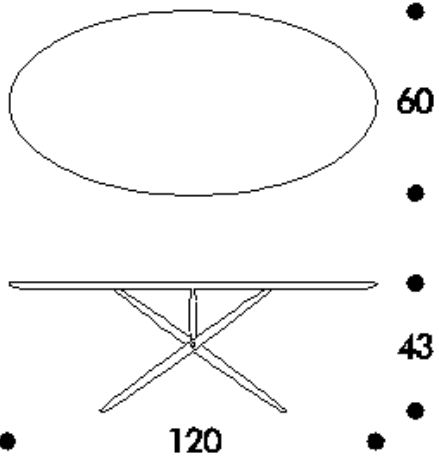

*The ovalette and Domino coffee tables are made by cabinetmakers with attention to detail. They originally belonged to the same furniture family as the wooden Kongo chair. In the first sketches they were called Kongo tables, but in the final drawings the names were changed.*

**artek**

# TEA TROLLEY 900

design Alvar Aalto 1937

Frame birch, natural lacquered

## Top

Edge birch, natural lacquered

Ceramic tiles, white or black

Rattan basket

## Wheels

white wheels, lacquered MDF

black rubber rings

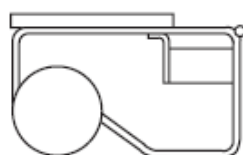
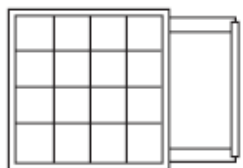

90

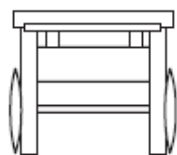

65



60

**artek**

# TEA TROLLEY 901

design Alvar Aalto 1936

Frame and top edge birch, natural lacquered

## Shelf alternatives

white laminate  
black linoleum

## Wheels

white wheels, lacquered MDF  
black rubber rings

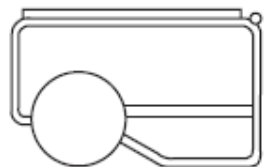

90

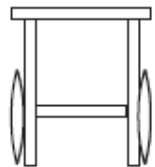

50



56

artek

OTHERS

**artek**

# OTHERS

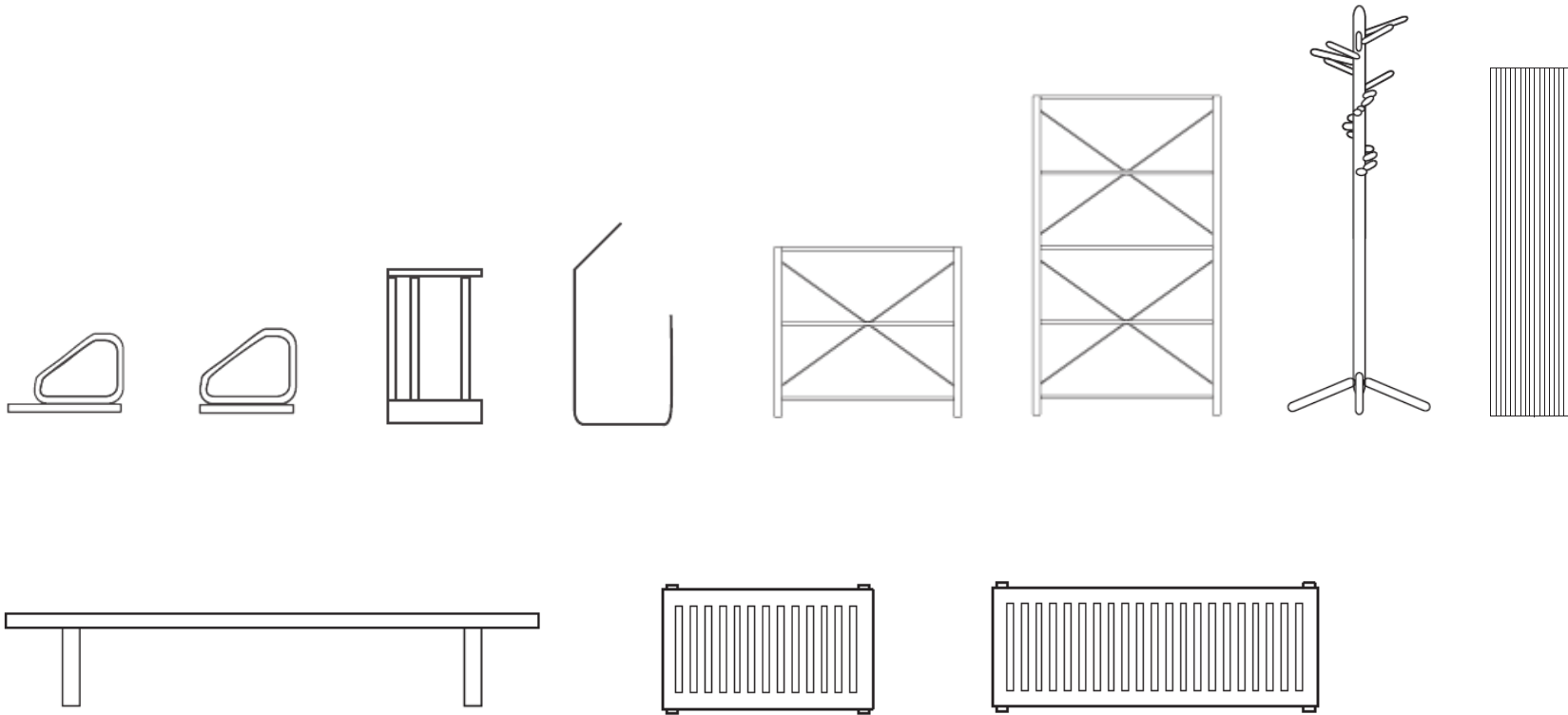

# BENCH 153A

design Alvar Aalto 1945

L-legs and top of birch

## Coating options

natural lacquered

white lacquered

black lacquered

grey lacquered

red lacquered

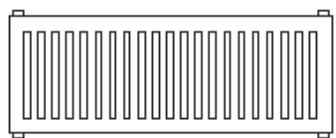

•  
44  
•

• 112 • • 40 •

# BENCH 153B

design Alvar Aalto 1945

L-legs and top of birch

## Coating options

natural lacquered  
white lacquered  
black lacquered  
grey lacquered  
red lacquered

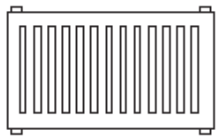

• 72 •



• 40 •

•  
44  
•

**artek**

# DAYBED 710

design Alvar Aalto 1933

L-legs, frame of solid birch, natural lacquered

Slat base solid birch

## Accessories

PU foam mattress 200 x 90 x 12 cm

with fire retardant cotton fabric

cover of Siena cotton fabric



92



35

203

**artek**





Artek Store Stockholm, Sweden 2010

**artek**

# SHELVING SYSTEM (HIGH UNIT)

design Naoto Fukasawa 2009

Ladder lacquered birch

Shelf painted MDF

Support zinc and aluminium

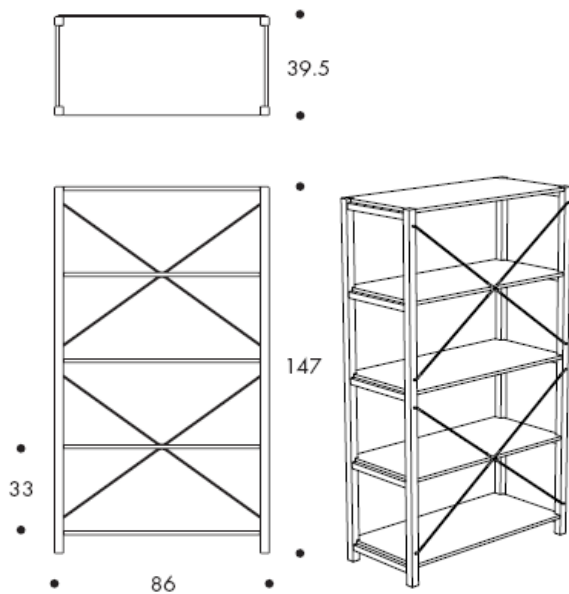

**artek**

# SHELVING SYSTEM (LOW UNIT)

design Naoto Fukasawa 2009

Ladder lacquered birch

Shelf painted MDF

Support zinc and aluminium

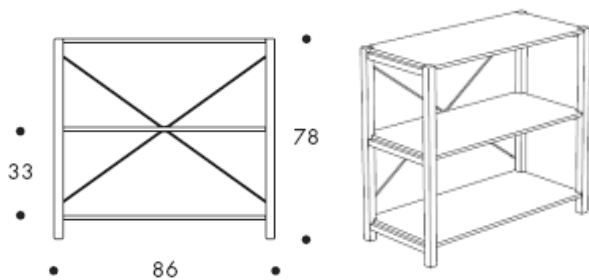
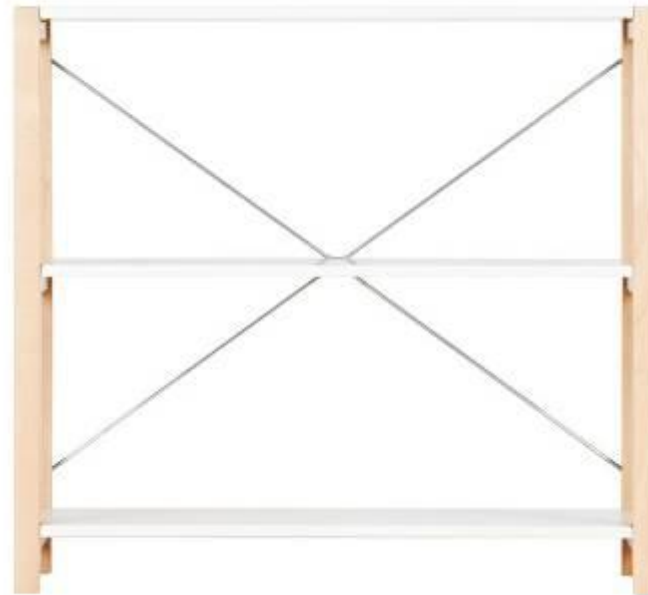

**artek**

# KANTO MAGAZINE AND FIREWOOD RACK

design Pancho Nikander 2004

Form pressed birch plywood

## Coating options

birch veneer  
natural lacquered  
white lacquered  
grey lacquered  
white lacquered  
rad lacquered

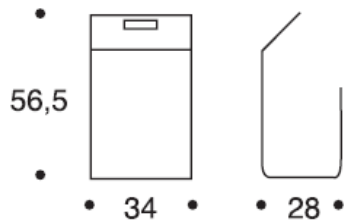

**artek**

# UMBRELLA STAND 115

design Alvar Aalto 1936

Birch, natural lacquered

Bottom brass



23

• 27 •

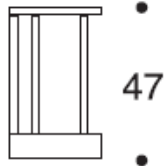

47

**artek**

# WALL SHELF 112A

design Alvar Aalto 1936

Birch, natural lacquered

Bottom brass

Holders birch

Shelf birch veneer

## Coating options

natural lacquered

white lacquered

black lacquered

grey lacquered

red lacquered

## Accessories:

wall list of solid birch, 120 x 6 x 2 cm

coating options as above



• 90 • • 25 • • 36 • • 90 • • 25 •

**artek**

# CLOTHES TREE 160

design Anna-Maija Jaatinen

Birch, natural lacquered

Metal foot black or white lacquered

Birch, frame and foot lacquered in  
white, grey, black or red

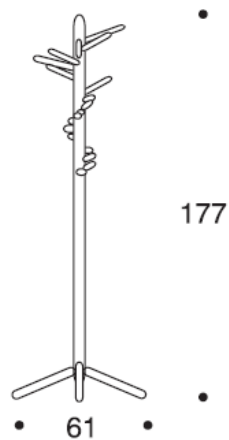

**artek**

# SCREEN 100

design Alvar Aalto 1933

Pine, natural lacquered

Rollable

Total length 200 cm

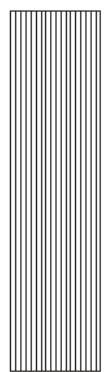

150

• 200 •

**artek**





Venice Biennale, Cafeteria, Venice Italy 2009  
Featuring screen 100, high chair 64 and other tailored products

**artek**

While valuing traditions Artek has at the same time entered a new era. Combining the ideology of the radical founders and a contemporary and dynamic approach to product development, the company is more art and tech than ever.



тел.: (812) 528 0265, 942 5979  
info@bogart.ru www.bogart.ru

ОРГАНИЗАЦИЯ РАБОЧЕГО ПРОСТРАНСТВА  
ОСНАЩЕНИЕ ОБЩЕСТВЕННЫХ ЗДАНИЙ

**artek**